

三相三线通用系列 Three-Phase and Three-Line General Purpose Series



安规认证 Approvals



特点和优点 Features and benefits

- ❖ 结构紧凑，安装快捷方便
Compact size, fast and easy chassis mounting
- ❖ 有效地适用于平衡和不平衡的三相负载
Effective for both balanced and unbalanced three phase loads
- ❖ 优越的传导衰减性能，电流范围广
Good conducted attenuation performance, wide current range

典型应用 Typical applications

- ❖ 电气和电子设备
Electrical and electronic equipment
- ❖ 医疗和商业设备
Medical and commercial equipment
- ❖ 自动化和工业测试设备
Automation and industrial testing equipment

技术参数 Technical specifications

额定电压 Maximum continuous operating voltage :	250VAC
工作频率 Operating frequency :	50/60Hz
额定电流 Rated currents :	5A ~ 150A @ 40°C Max.
耐压试验(一分钟) High potential test voltage(1 min) :	Line to Line 1500VDC / Line to Ground 1500VAC
工作和储存环境温度 Operation and storage temperature range :	-25°C~+85°C (25/085/21)

型号 Filter	额定电流 Rated current @40°C [A]	泄露电流 * Leakage rate * 250VAC/50Hz [mA]	电容 Capacitance Cy [nF]	电阻 Resistance R [kΩ]	端接方式 Terminal connections	电路图 Electrical schematic [fig.]	外形尺寸 Dimensions [fig.]
AG3101-5-33	5	< 0.5	4.7		- 33	1	1
AG3101-10-33	10	< 0.5	4.7		- 33	1	1
AG3102-5-44	5	< 0.5	4.7		- 44	1	2
AG3102-10-44	10	< 0.5	4.7		- 44	1	2
AG3201-15-55	15	< 0.5	3.3	1500	- 55	2	3
AG3201-20-55	20	< 0.5	6.8	1500	- 55	2	3
AG3201-25-55	25	< 0.5	4.7	1500	- 55	2	3
AG3201-30-55	30	< 0.5	2.2	1500	- 55	2	3
AG3201-40-55	40	< 0.5	6.6	1500	- 55	2	4
AG3201-50-55	50	< 0.5	6.6	1500	- 55	2	4
AG3201-65-55	65	< 0.5	6.6	1000	- 55	2	4
AG3201-80-55	80	< 1	10	1000	- 55	2	5
AG3201-100-55	100	< 1	10	1000	- 55	2	5
AG3201-150-55	150	< 1	50	1000	- 55	2	5

* 最大泄漏电流是在正常状态下测得，注意如果中线断开，最坏情况下泄露电流可能达到两倍以上。

Maximum leakage under normal operating conditions, note: if the neutral line is interrupted, worst case leakage could reach twice this level.

电路图 Electrical schematics

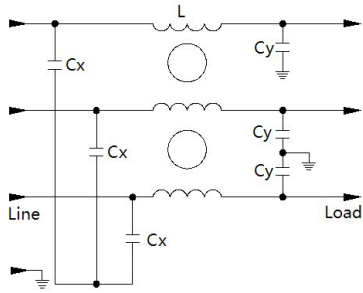

fig. 1

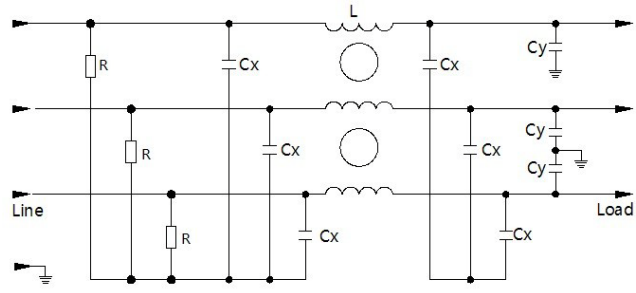
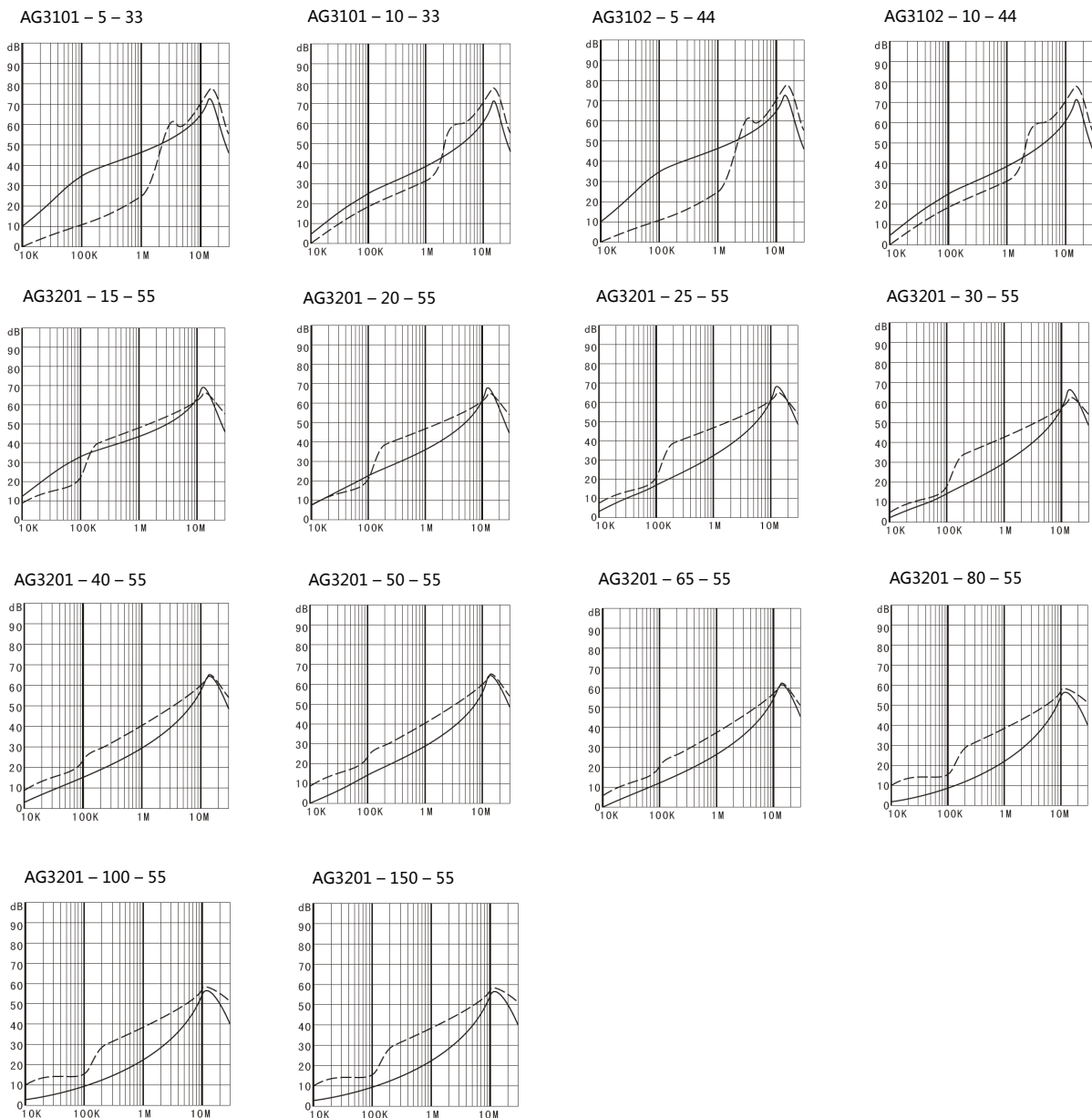

fig. 2

典型衰减特征 Typical filter attenuation

Per CISPR 17/50Ω system [——— 共模 Common mode ; - - - - - 差模 Differential mode]



外形尺寸 Dimensions [All dimensions in mm]

端接方式 Connections style "- 33"

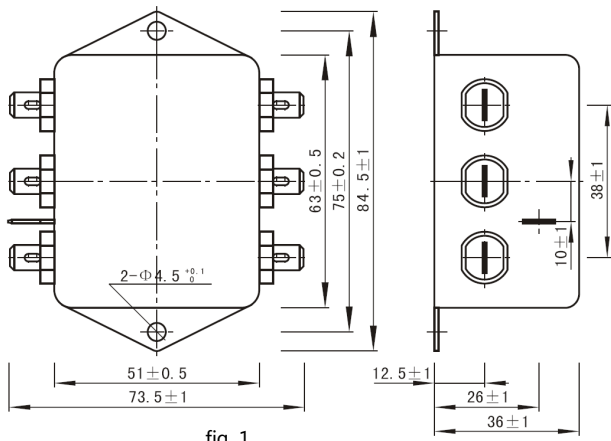

fig. 1

端接方式 Connections style "- 44"

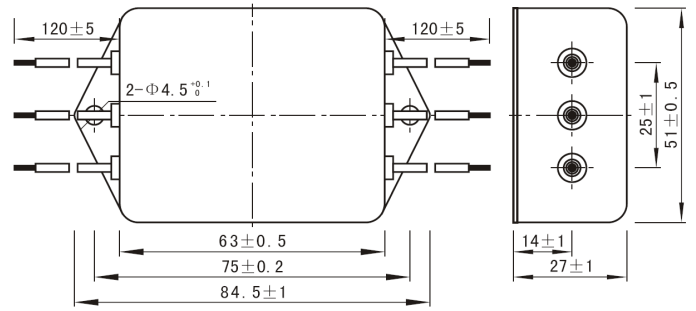

fig. 2

端接方式 Connections style "- 55"

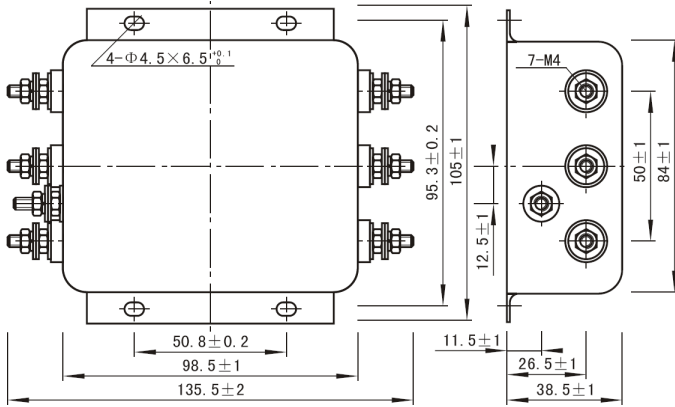

fig. 3

端接方式 Connections style "- 55"

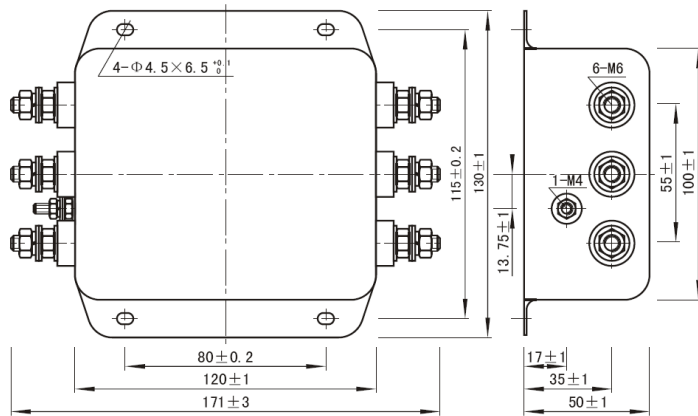

fig. 4

端接方式 Connections style "- 55"

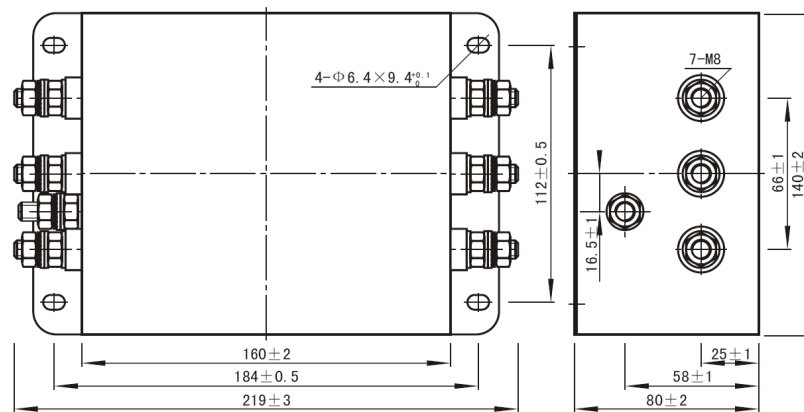

fig. 5